

# Hand Pallet Trucks

## Technical Information

### Structural

- Precision aligned frame and wheels, with high quality bearings to reduce friction and wear, ensuring smooth effortless operation.
- Forks are manufactured using quality high tensile steel, fabricated in a one piece "C" section for greater strength and durability.
- Nylon entry and exit rollers ensure smooth, easy entry and exit to pallets.
- Clever design features extra protection for the load wheels.
- Stainless Steel option is available for the Frame or entire unit.

### Hydraulic System

- Has the power to easily lift loads even when operating the Unit to its full capacity.
- Lowering of the load is smooth, gentle and stepless.
- Built in Hydraulic relief valve ensures the unit can not be overloaded and cause damage to the frame.
- The Pump Unit is fully sealed. Protecting penetration of the unit from moisture contamination of the oil or critical internal moving components.
- The handle operates in three positions.  
**Lift, Lower and Neutral** for simple ergonomic, single handed operation.

### Options

- Choice of Nylon, Polyurethane or steel, Load and Steer Wheels.
- All Models are available with single or tandem Load Wheels.
- A range of Fork Widths are available to suit all applications.
- All Stainless Steel Units are available across the entire model range.
- Most Models are available with either foot or Hand Brakes.
- Scissor Lifts.
- Weighing Scales.
- 4 Wheel Steering.
- Galvanized.
- Low profile and High Lift Units.
- Quick Lift Models.  
( 4 Pump Strokes to Maximum Height )



Measurement	Model	Dimensions and Specifications
A. Rated Capacity	EL20	2000 kg
	EL25	2500 kg
	EL30	3000 kg
B. Overall Fork Length	All Models	1135 mm
C. Overall Length	All Models	1535 mm
D. Fork Width	All Models	160 mm
E. Overall Fork Width	Narrow	540 mm
	Standard	680 mm
F. Fork Lowered Height	All Models	75 mm
G. Fork Maximum Height	All Models	195 mm
H. Lift	All Models	120 mm
I. Load Wheel Position	All Models	185 mm
J. Steer Wheel	All Models	180 X 52 mm
K. Load Wheel	All Models	72 X 90 mm
L. Weight	EL 20	78 kg
	EL 25	82 kg
	EL 30	90 kg

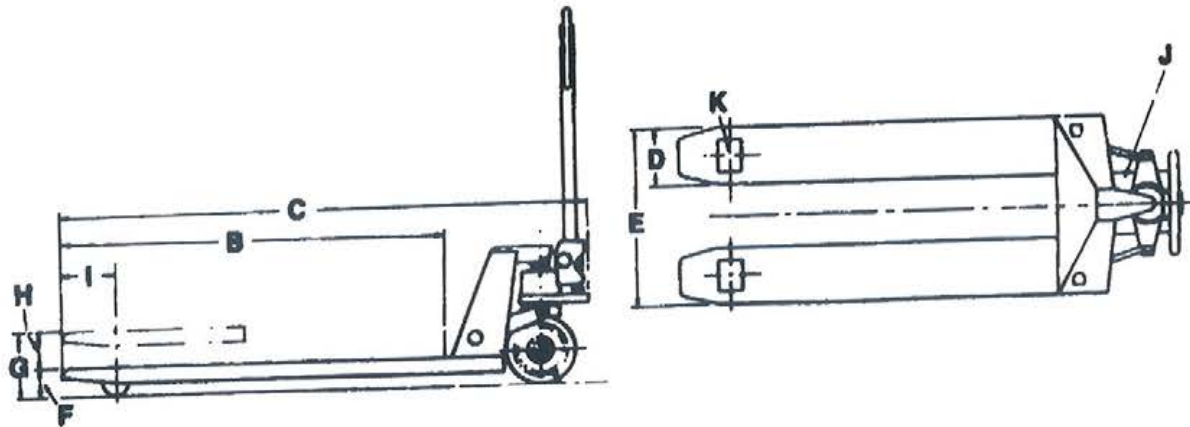

For more information on our  
Product and Services please call:



Sales & Rental: (65) 6662 2211  
Parts: (65) 6662 2275  
Service: (65) 6662 2215

[metaquip@tanchong.com](mailto:metaquip@tanchong.com)

**MQTC**

Distributor:  
MetaQuip T C Industrial Pte Ltd  
23 Jalan Buroh Singapore 619479  
Tel: (65) 6265 3666  
Fax: (65) 6264 1666



[www.tanchong.com](http://www.tanchong.com)